

bw monitor

Just monitoring ballast water



Frequently Asked Questions

Document for Distribution

Version 01 (August 2020)

Ballast Water Monitoring A/S · Nymøllevej 50 · 2800 Kgs. Lyngby · Denmark

T: +45 27 82 54 48 E: info@bw-monitor™.com

CONTENTS

Introduction	3
The questions	4
Applicability for performance monitoring	4
Indicative compliance	5
Tests, sea trials and certifications	6
Technical issues	7
Ease of use	9
Design and specifications	10

Introduction

"in-line and on time"

The company Ballast Water Monitoring A/S is registered in Denmark and was created to give ship-owners the option of having performance information on their Ballast Water Management System, when it is useful rather than when it is too late.

The two founding companies LITEHAUZ ApS and Medico Chemical Lab have developed a monitoring device that can survey the functionality and biological efficacy of a BWTS automatically, continuously, directly in the ballast line and already on ballasting while the equipment is running. We like to think of this as 'in-line and on time'. The result is the **bw-monitor™** that can measure and report on pre-treatment performance and the disinfection unit's efficacy in due time for a re-run, repair or re-treatment.

The **bw-monitor™** has been tested in the lab-scale, land-based full-scale facilities and has been installed and operated on board vessels. The monitoring system can provide performance indications in both marine and fresh water, warm and cold water, and with the typical disinfection techniques, such as electrolysis, chemical treatment and UV.

The **bw-monitor™** is designed to be fully compatible with accompanying software. The software's built-in algorithm automatically adjusts monitor to the incoming water characteristics and analyses key water parameters by giving an instant BWTS status indication for the operator of the system. The monitoring system can also be accessed remotely for software and algorithm updates. The data collected by the system is encrypted and stored in the information management facility on-board the vessel and can be sent to a **bw-monitor™** cloud storage facility for back up or later analysis together with other data i.e. water temperature, salinity, vessel specific data, geoposition data and tidal information.

It is important to realize that the **bw-monitor™** firstly is a performance monitoring device for your BWTS to be used for predictive maintenance and help in OEM communication, and only secondly an instrument that can provide organism numbers for indicative compliance. The **bw-monitor™** works on uptake and will only monitor on discharges, if you chose to set it up to do that.

The questions

Applicability for performance monitoring

How does it work?

The **bw-monitor™** analyses two key locations in the ballasting process and compares 'before' and 'after' levels. The positions are before any pre-treatment (i.e. typically a separation unit) and after the treatment unit. Data are displayed to the crew and logged in a data storage device, for inspection by port state control when required. The **bw-monitor™** can be fitted with a communication line to a central onshore data repository, allowing for simple back up of data and for detailed analytical processes.

Does it work with all ballast water management systems in all waters?

Yes. The monitoring system can provide performance indications in both marine and fresh water, warm and cold water, and with the typical disinfection techniques, such as electrolysis, chemical treatment and UV.

Can I move it to be used on another vessel?

Yes, but it is a fixed installation and you need to install the necessary flanges to mount the monitor on the ballast pipe.

Where has bw-monitor™ been tested?

The **bw-monitor™** has been tested in the lab-scale, land-based full-scale facilities and has been installed and operated on board several vessels. It has been tested on an electrochlorination system, several UV systems and a heat treatment system.

Do I need to do anything?

No. The specifications of BWTS will allow BWM A/S decide on two performance criteria levels - one for filter and one for disinfection unit, but default values applicable across the industry are included. Both criteria are basically a number defining how large the reduction is between "before" and "after" and they are part of the installation procedure.

Is the bw-monitor™ system set up specifically for each brand?

The system is set up for each technology, e.g. UV or electrolysis, rather than brand-wise. Electrolysis has a higher and faster kill rate than UV, so our default value is higher.

Has the bw-monitor™ been installed on ships?

Yes. It has been installed on several ship types: oil tanker, bulker, LPG tanker, container. The systems are mostly still onboard. The longest >48 months.

Installation time

Pre-works are conducted in shipyard to mount T-pieces, spools or studs in the ballast pipe blinded off. This will typically also include the pulling of cables and installation of control cabinet. Installing the bw-monitor™ system takes 1 day, in some cases 2 days.

Indicative compliance

Can it be used for testing D-2 compliance?

No. The bw-monitor™ is developed as an onboard self-monitoring system. It does not provide information for organisms specified to the size ranges of the D-2 criteria and it does not count organisms or micro-organisms (reference to BWM.2 Circ.42 rev.1). So, as it does not provide a value directly comparable to the D-2 standard the answer is No.

Why does bw-monitor™ not give a D-2 indicative compliance value?

It is currently not the objective of the bw-monitor™ to convert fluorescence to "number of algae" for use in port state control. The reasons are the following:

- The bw-monitor™ works on uptake. It does not monitor discharge directly unless specifically set up to do that at client request.
- the monitor's output value includes the UV induced fluorescence response from smaller (>10um) and larger algae (>50um);
- the conversion factor needed to provide a number of live algae in natural water is still not considered sufficiently robust for global application;
- last but certainly not least, we do not want to engage in validation tests according to upcoming IMO or USCG protocols until we have more data and the guidance is clear.

Can it be used for testing indicative D-2 compliance?

Yes, based on the fluorescence measurements and with a measurement on discharge but this is not the standard set-up. But since the UV induced fluorescence output "after" is the viable algae's response this can be used for indicative D-2 compliance assessment. The data set can be used to roughly indicate the number of living organisms in the size range 10-50 um, which are predominantly microalgae, i.e. "to provide a quick, rough estimate of the number of viable organisms" according to BWM.2 Circ.42 rev.1.

What about compliance at discharge?

The system is designed to monitor the BWTS and it works when the BWTS is working. So, for most BWTS that is on uptake, and for UV and any other systems additionally treating on discharge, it will also monitor the BWTS on discharge, if the piping is set-up to allow that.

Does a shipowner have to surrender data to PSC from bw monitor?

We want to advantage of the non-criminalization or experience-building phase of 2-3 years proposed by IMO and have decided that the system is a voluntary self-monitoring system.

- No. In our standard set-up the bw-monitor™ is not a D-2 indicative compliance system, and, while being a self-monitoring system, it does not report in design limitations required in the TA, one does **not** have to report such data to PSC.
- However, having the data to provide indicates that you are in good faith.
- If you have set the bw-monitor™ up for D-2 indicative compliance monitoring on discharge, you may be asked for data by PSC in the future.

Tests, sea trials and certifications

Has bw-monitor™ been validated?

The bw-monitor™ has been validated in-house using a well-known onboard kit used for commissioning of BWTS (PAM fluorescence; bbe 10cells) and in addition with the standard USCG test method CMFDA during full scale tests with BWTS.

It is expected that IMO will issue guidance (2020 or 2021) for indicative compliance monitoring devices. It is expected that bw-monitor™ will seek this validation once the guidance is ready.

Has Class certified the system?

Yes. The monitor has been certified the environmental tests of all BWTS, i.e. for pressure, humidity, temperature, vibrations and EMC (radio noise). Tests were performed by the FORCE/ DELTA laboratory and the certification is by DNV GL.

Type approval

The bw-monitor™ is a voluntary self-monitoring system collecting data for the purpose of BWTS manufacturer and shipowner. It is therefore a non-essential system and does not monitor design limitations of the BWTS. It does not require certification type approval.

Technical issues

What is the monitoring principle?

The two basic techniques are optical and is therefore non-intrusive and non-destructive. Viable algae are measured by emission of light (fluorescence) after excitation with UV light. Particle density is measured by the scattering of laser light.

How do you know a dead from a live algae?

The use of active fluorescence to measure photosynthetic activity has been a generally accepted method for two decades. Most methods use a flash stimulated fluorescence to measure photosynthetic activity as a sign of life. This technique is almost similar to the instruments of Hach, Turner, Chelsea and bbe Moldaenke. The difference is that bw-monitor™ does not use pulses to lower detection limit (PAM).

How do you calculate viable vs non-viable (live vs dead)?

Variable fluorescence F_v is measured as the difference between a low level, steady state fluorescence F_o and the level of a fluorescent transient F_{max} . The difference between the two levels is a measure of the functionality of the photosynthetic (PS II) system of the algae.

The content of living phytoplankton is determined by calculating the variable fluorescence

$$F_v = (F_{max} - F_o).$$

The minimal fluorescence is determined by using a pulsating light source with preferably 20 ms to 100 ms intervals and a wavelength of 420 nm. To reach the state for determination of the minimal fluorescence

faster, a light source with a wavelength longer than 700 nm is used. The maximal fluorescence is determined by using continuous light source with a wavelength of 680 nm.

The fluorescence is measured by the photodiode and in combination with a preamplifier, a multiple feedback filter, a demodulator and an integration filter the electrical signal is transmitted to an ADC input on the main processor.

Thus, the measured parameters of phytoplankton and particles include F_0 and F_{max} , and the light scattering values, which are measured in three different positions. F_v and $F_v:F_{max}$ are calculated by software.

How does laser scattering for particles work?

As providing information related to the particle size and particle concentration is of great importance in the monitoring of the ballast water compliance, the apparatus is equipped with a light scattering unit. The light scattering unit is a pulsating laser module generating pulsating light with a wavelength of 650 nm. The laser light transmitted and the diffraction is measured at 0, 5, and 25 degree angles.

The light scattering device is calibrated with priority to a reference particle size standard that allows determination of particle sizes in the range of 10–100 μm . The light scattering measurement is included in the continuously measuring cycle. Currently, only density is monitored, not size.

Is laser scattering related to turbidity

Yes. The center diode reports on the light passing the solution and while the data cannot be taken as turbidity directly (as that must follow a specific technology) a linear correlation can be established from approx. 5 mg/L and up.

How long does a measurement take?

The response for each parameter may be logged in real time. i.e. in 20 to 100 milliseconds, with a total sample cycle of 0.5 sec to 2 sec.

- o. A dark period in which the sample is fed to the measuring position. In this period the sample is not exposed to light.*
- 1. A period of low light intensity, measuring the fluorescence from dead and living algae in the phytoplankton.*
- 2. A period of intense light measuring the fluorescence from dead and living algae.*
- 3. A period of light scattering measurements.*

How wide a range of algae does it measure?

The bw-monitor™ provides an indicative result regarding the performance of the BWTS between >5000 algae per mL and 50 algae/mL. Each point on the graph represents 20 averaged sampling points in one monitoring cycle. The standard deviation of the group of measurements is +/- 1.5.

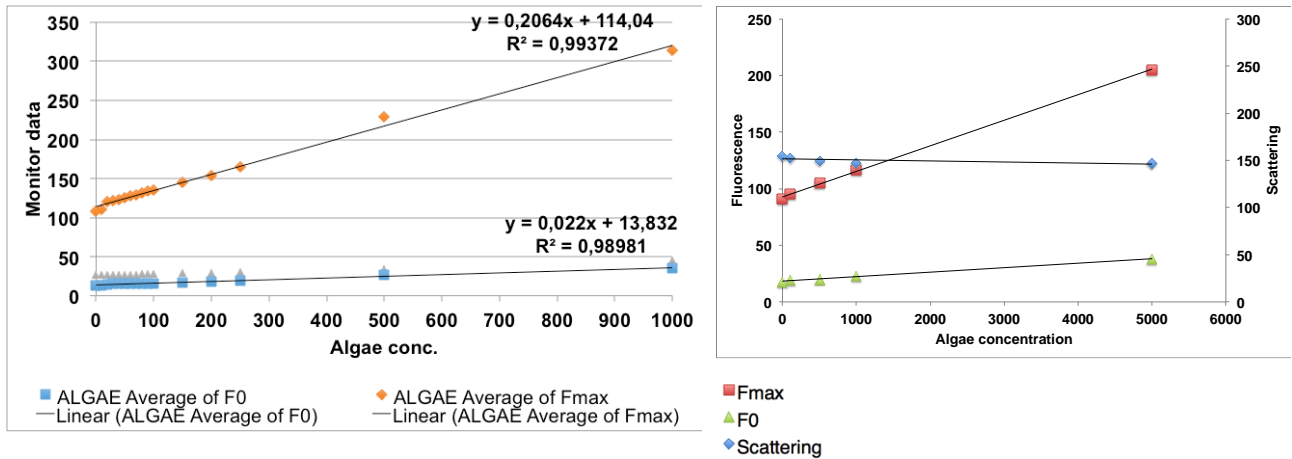

bw-monitor™ response with variable algae concentration (left 10-1000 algae/mL; right 50-5000 algae/mL).

Ease of use

Do you have to do anything to operate it?

No, there are no removal or manipulation of samples nor any addition of chemicals. Therefore, no operating costs.

The built in system is designed to allow algorithm update mode – the administrator can remotely update the algorithm with “push-updates”. It removes the necessity of user hassle with installation.

How do I program it and install software?

You do not need to programme anything. A specially designed .NET-based application, which is installed on the PC connected to bw-monitor™, has been created in order to control, gather and analyze incoming data from bw-monitor™.

Will it tell me anything onboard on the ballast water?

Yes. You will get alerts with an intuitive color code:

- a. Waiting for input from sensors
- b. Water is clean and treatment is not necessary
- c. Treatment status is OK
- d. Alarm mode – treatment does not meet requirements
- e. Cannot connect with sensors / service mode

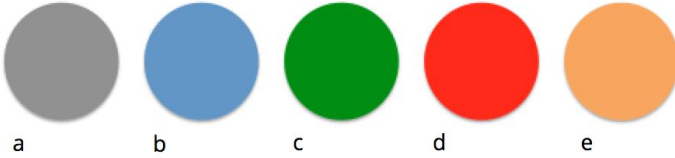

The user receive a tamper proof status report at the end of each ballast operation.

What if the water is very green with algae or other organisms?

The software is designed to self-adjust its critical (error level) values by adjusting the functional settings of the bw-monitor™ itself through a three step procedure at interval. If there are many algae it will become less sensitive and *vice versa*.

Design and specifications

How does it look?

The bw-monitor™ is designed as a bipolar device with the two legs extending into the ballast pipe. One leg contains sources of light emission (UV LED diodes and laser module) and the other measures the light scattering in three positions. Perpendicular to the light path, the fluorescence signal is detected in a silicon photodiode provided with a long pass filter. The laser light transmitted and the diffraction is measured at 0, 5 and 25 degree angles.

The housing is currently available in stainless steel fitted with the necessary filters and glass. The power required is standard 230 V to a power supply provided as part of the monitoring system. Raw data and computed results are logged locally by the device and/or sent to a data repository and computational facility.

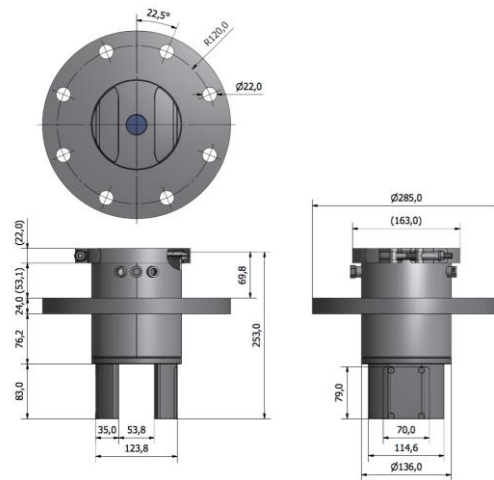

Physical installation

The bw-monitor™ is designed for installation inside the ballast line in two locations (one monitor in each). The monitor fits into a 150 mm (6") side arm that can be welded onto the ballast pipe and fitted with a DIN standard flange and blinded off in advance of the actual mounting of the sensor. The bw-monitor™ will be fitted with a similar flange for the DIN standard pipe and is installed on board. It can be delivered as a ready-to-install T-piece in the appropriate diameter of the BWTS. The bw-monitor™ does not require a separate pump.



Does it block the water flow?

The water flows and conditions for monitoring water and particles suspended in the water has been modelled by computational fluid dynamics (CFD) isokinetic sampling (modelling by FS Dynamics, Gothenburg). Test of pressure drop 250 m³/h in 150 mm (smallest possible installation) and 250 mm diameter pipes. Pressure profile in 150 mm diameter pipe from -0.2 m to outlet: – 8.4 kPa (a lot!); and the pressure profile in 250 mm diameter pipe showed a pressure drop of – 0.2 kPa (not a lot).

Representativeness of the sampling and data?

During the entire duration of BWTS operation, the water is sampled from the two positions and the readings of particles and fluorescence 'before' and 'after' are compared.

The bw-monitor™ does not remove a side stream or sample volume *per se*, but monitors the volume of water between the two legs of the device as the water flows past the diodes.

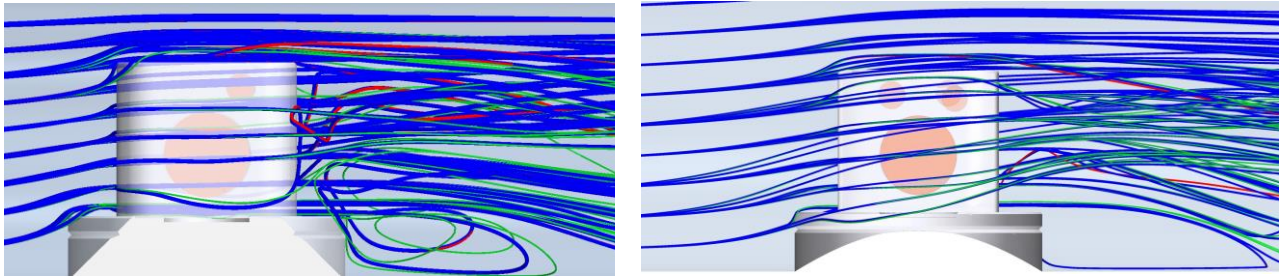

Particle trails in **150 mm** (left panel) and **250 mm** pipe (right panel)

Ref Particle: 15 μm , 0.998 g/cm^3
Particle 1 : 15 μm , 1.1 g/cm^3
Particle 2 : 150 μm , 1.7 g/cm^3

Even the larger and dense particles (150 μm , 1.7 g/cm^3) follow the water quite closely, and it is assessed that **no significant** particle concentration difference is expected from the ballast water as a whole, and the section of water monitored by the **bw-monitor™**.

If you send data to shore, can it be hacked?

No. The software is also designed to send an encrypted data log from the measurements to specially designed and software compatible cloud storage, when Internet connection becomes available.

What can I do with data?

If you chose you can store your performance data for PSC. You can share with you technical, compliance and/or procurement staff. The BWTS manufacturer may use data for analysis, and you have the option to use BWM Cloud for storage, backup and analysis of data. All data that stored on the BWM Cloud are encrypted.